

# Semi-Auto Debagger



**Custom equipment for  
bottlers and blowmolders**

**The Cost Effective Method  
to Supplement Your Filling  
Requirements**

**The Semi-Automatic Belt Accumulation Debagger is a machine that is used for simple and rapid reintroduction of single tier bagged bottles into a production Line. The machine utilizes a cold knife bag opener for enhancing performance.**



**The Semi-Automatic Debagger is built to CE and OSHA specifications using the latest technology from Allen Bradley or Siemens depending on customer preference. SMC is used for all pneumatic components.**



## Semi-Auto Debagger

*We design, engineer and build each system for your specific needs.*

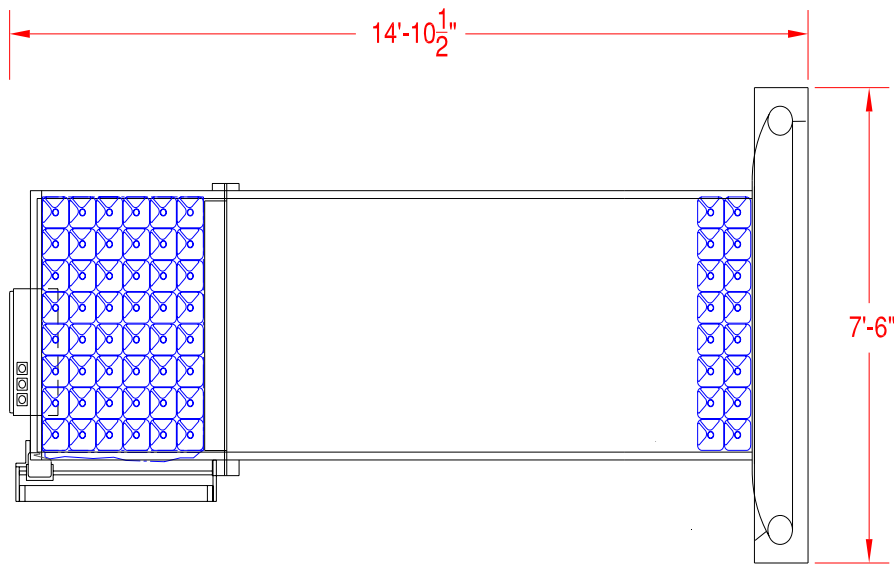

**Square Bottle  
Debagger with  
Cold Knife  
Cut-Off and  
Accelerator**

**Expandable in 4' Sections**

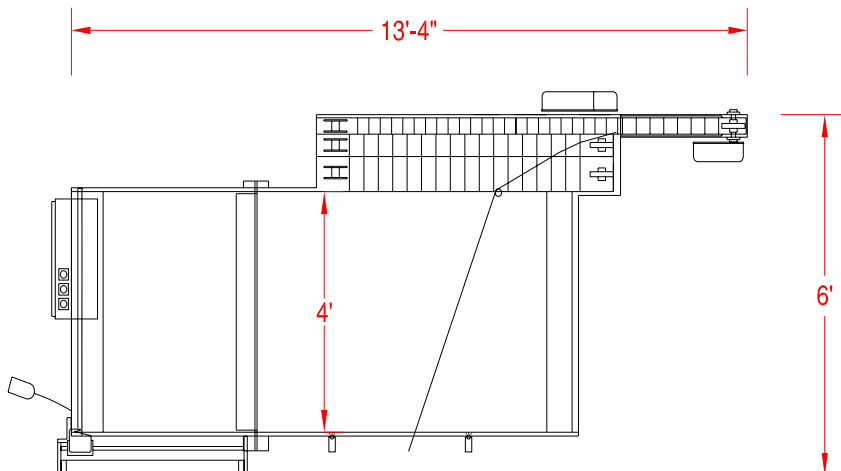

**Round Bottle  
Debagger with  
Cold Knife  
Cut-Off and  
Single Filer**

### **Northern Equipment & Conveyor Co.**

3035 New Butler Rd.

PO Box 8504

New Castle, PA 16107

Phone: (724) 924-9680

Fax: (724) 924-9665

Email: [Sales@NECCo.us](mailto:Sales@NECCo.us)

[www.necco.us](http://www.necco.us)